

Poseidon RS-485 wiring examples

Poseidon 2250

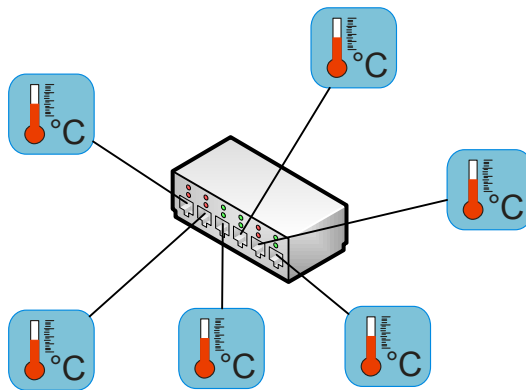

Variants of RS-485 industrial bus wiring for Poseidon sensors connection.



STAR topology

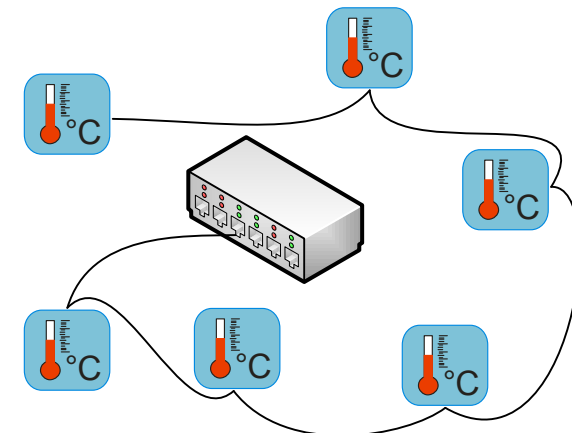

Daisy chain topology

(2) Poseidon bus types

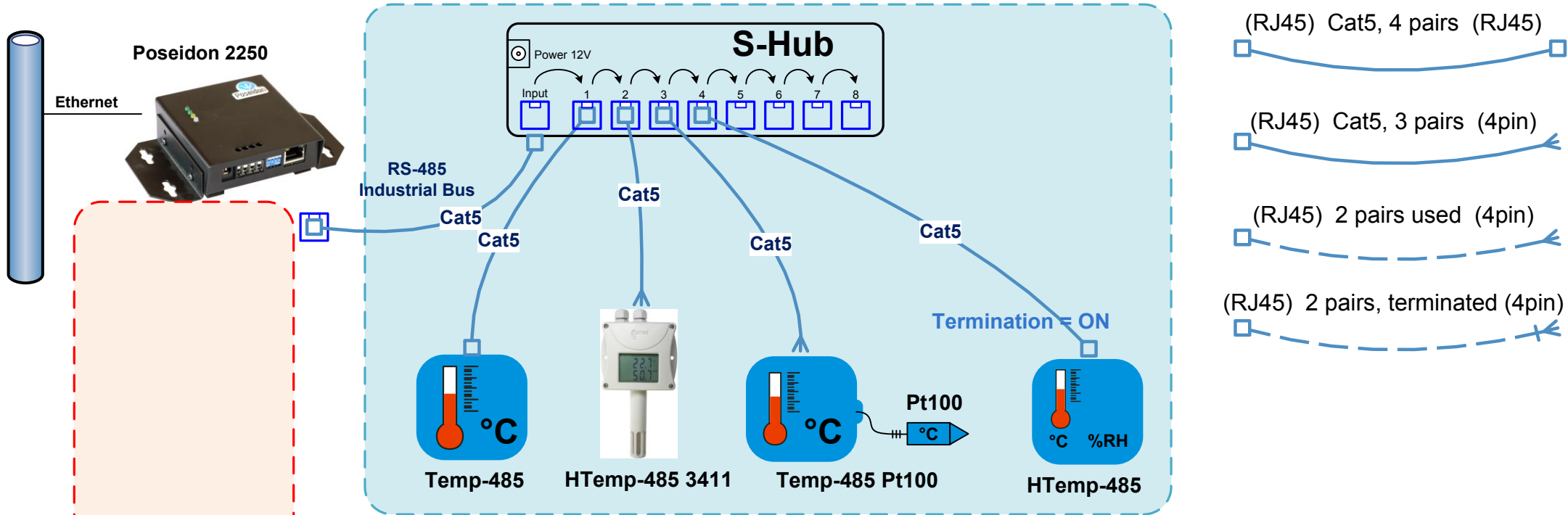

1-Wire: RJ11 (UNI)

- Short distance (20/60m)
- Max 10 sensors on one bus
- Telephone cabling
- Telco & IT applications
- Easy to use
 - Unique ID autodetection
 - Non termination required

1-Wire bus
RJ11

RS-485: RJ45 & 4pin

- Long distance up to 1000 m
- Max 31 sensors
- Cat5 or any 2 pairs cabling
- Industrial applications, high precision sensors (with display)
- Wiring rules
 - Unique address per sensor required (jumpers or setup)
 - Last sensor have to be terminated (120 ohms resistor)

(3) 1-Wire: Wiring options

Ethernet

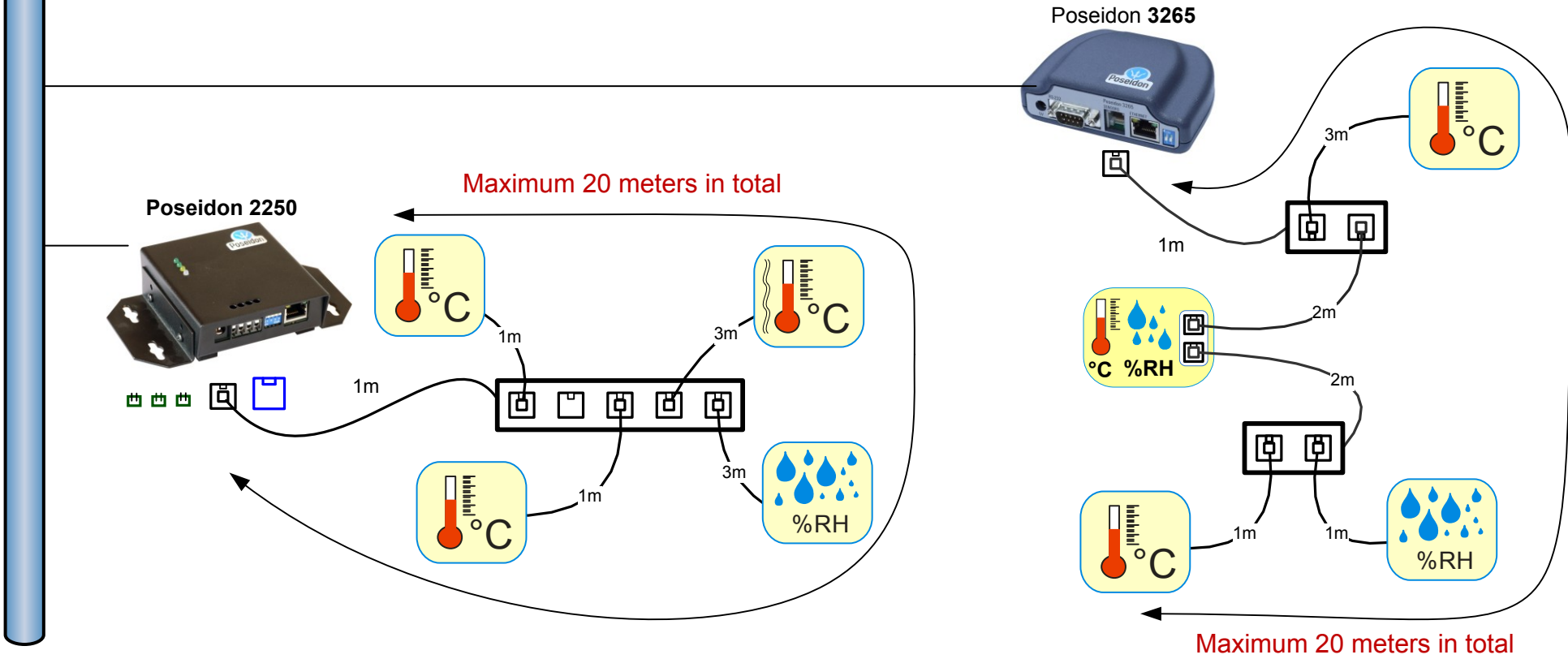
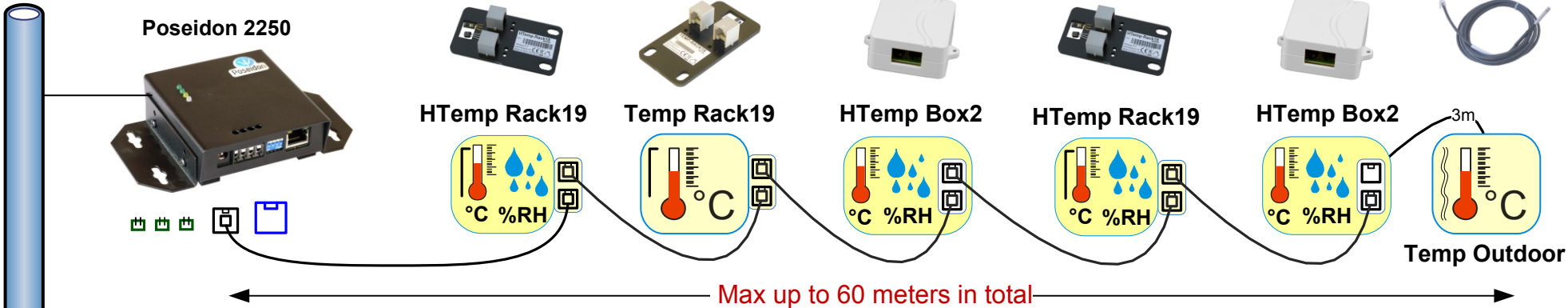

(4) RS-485 Spiders in “daisy chain”

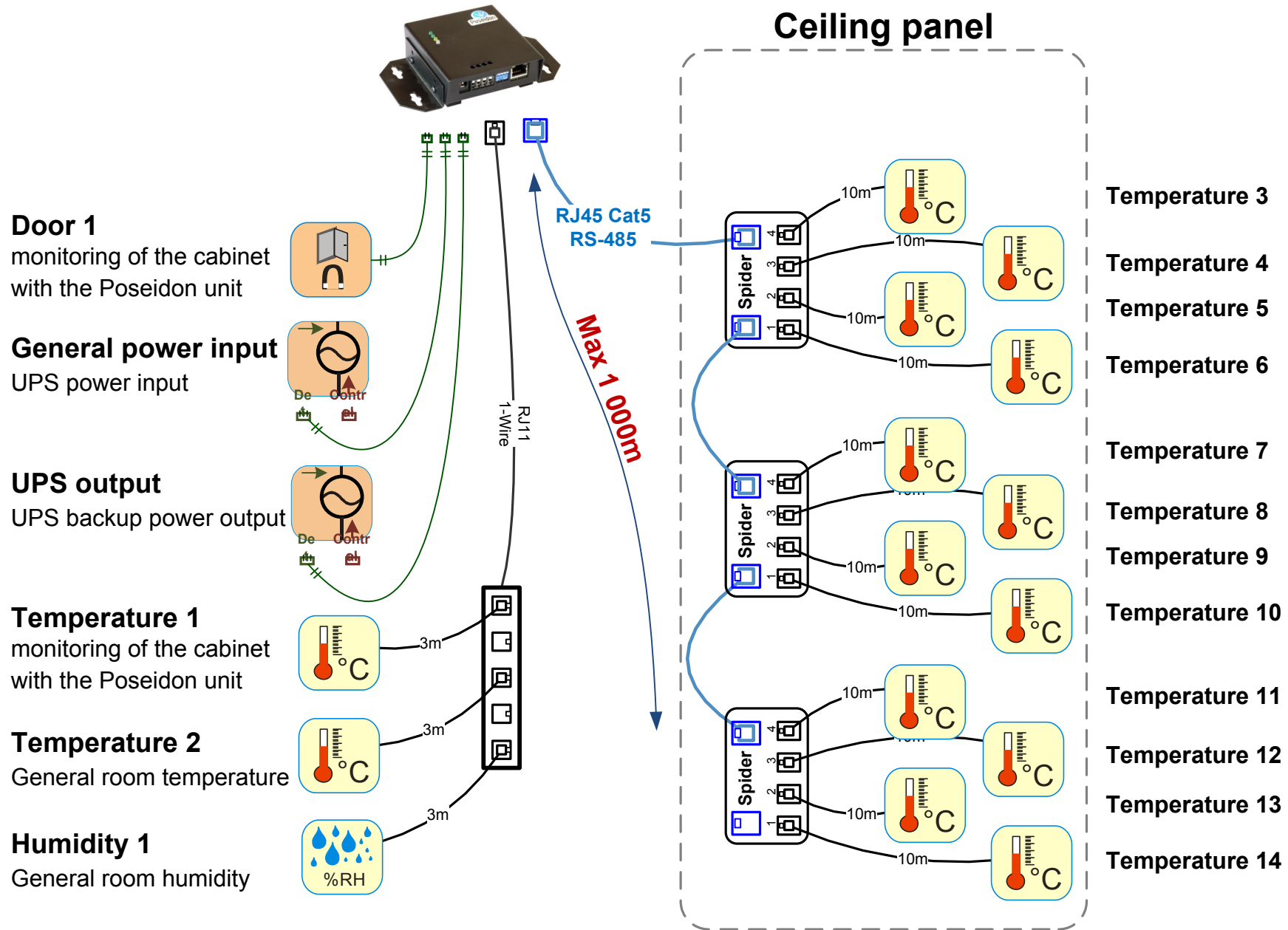

(5) RS-485: S-Hub "star" principle

S-Hub Connecting rules

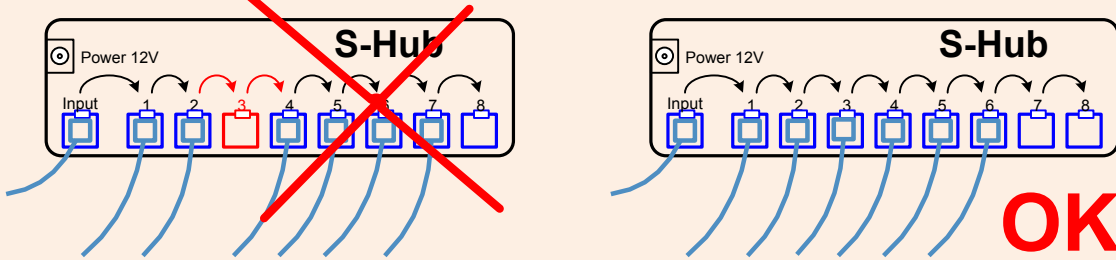

S-Hub principle scheme

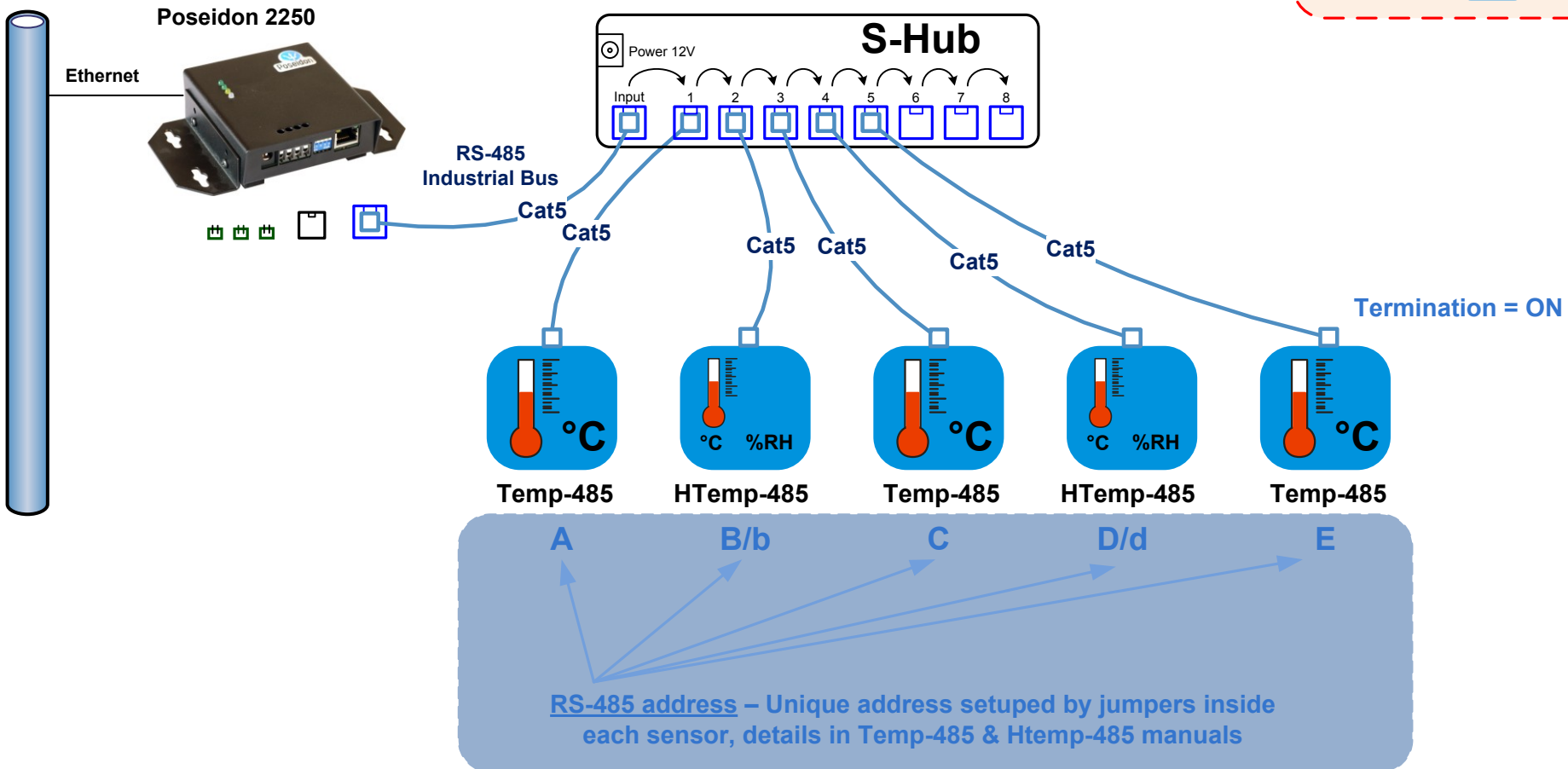
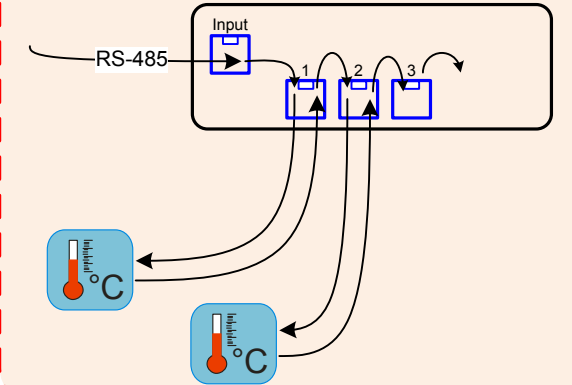

(6) RS-485 / S-Hub "star" with Spider included

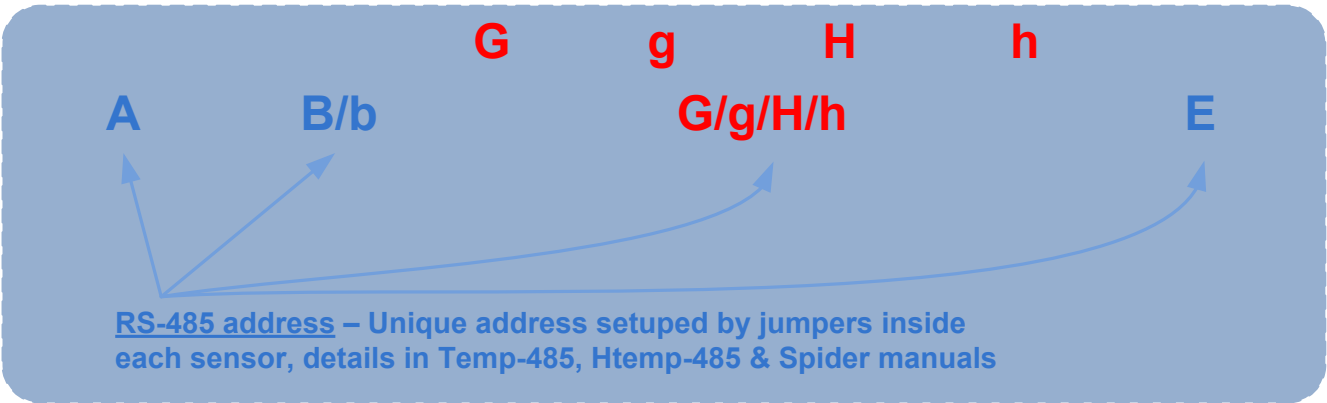
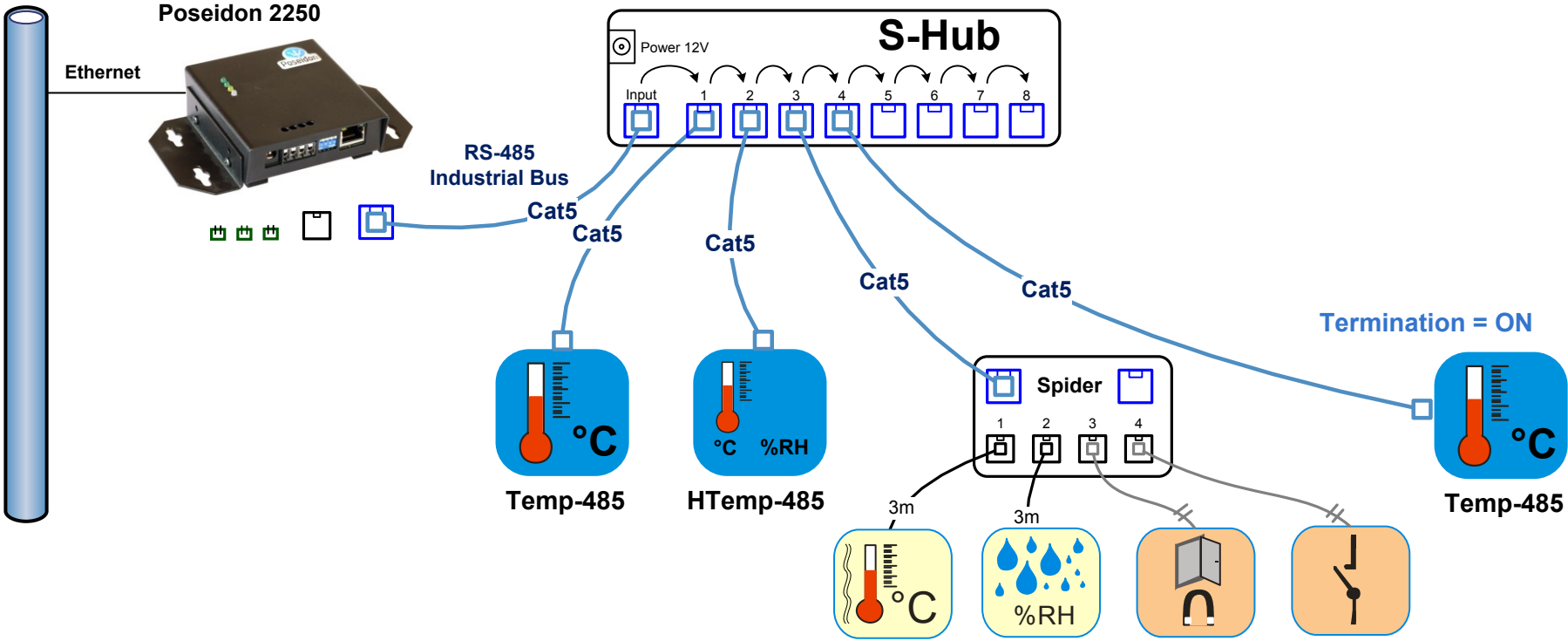

(7) RS-485 / S-Hub "Stars combination"

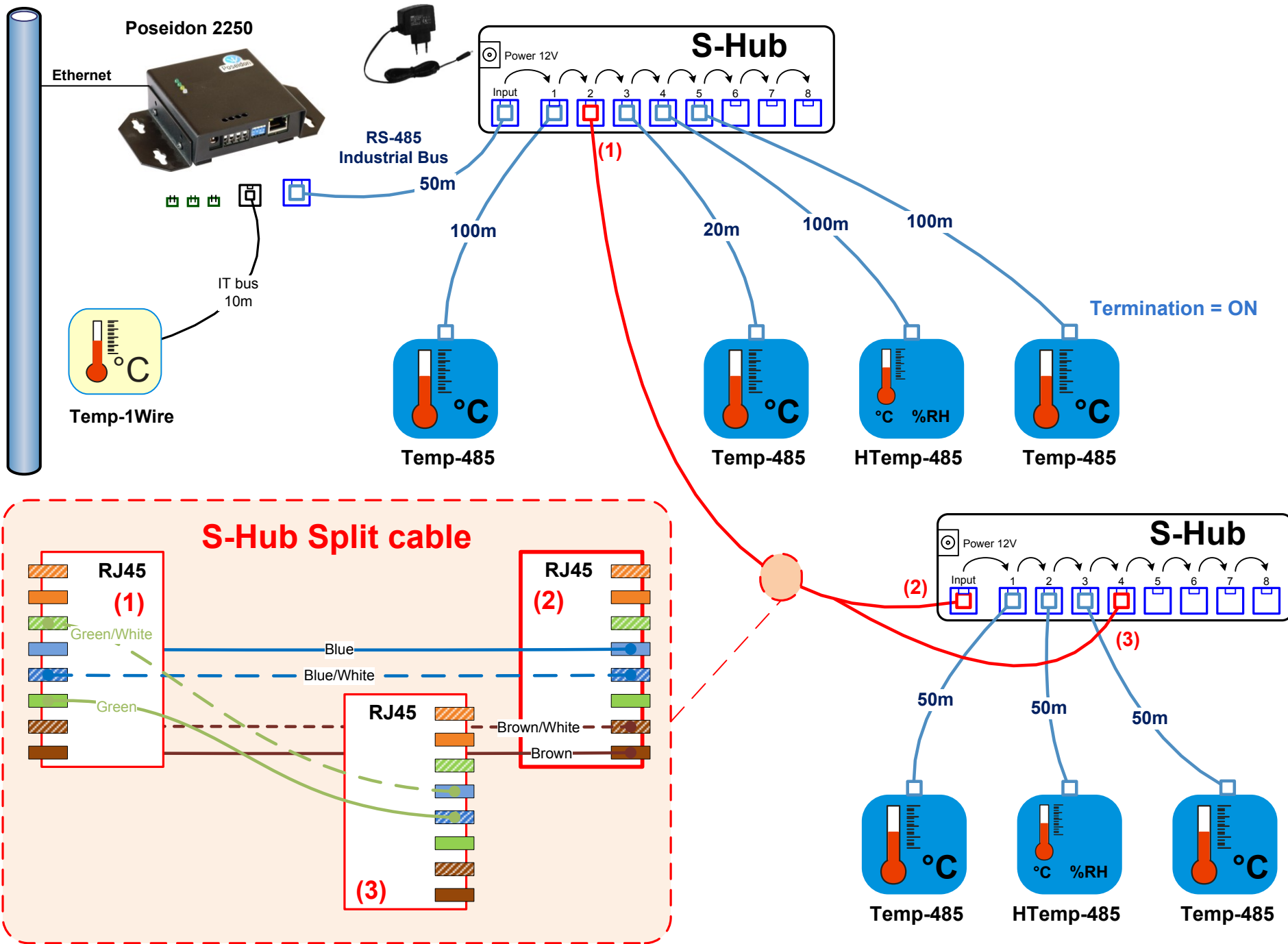

(8) RS-485: RJ45 / 4 pin wiring

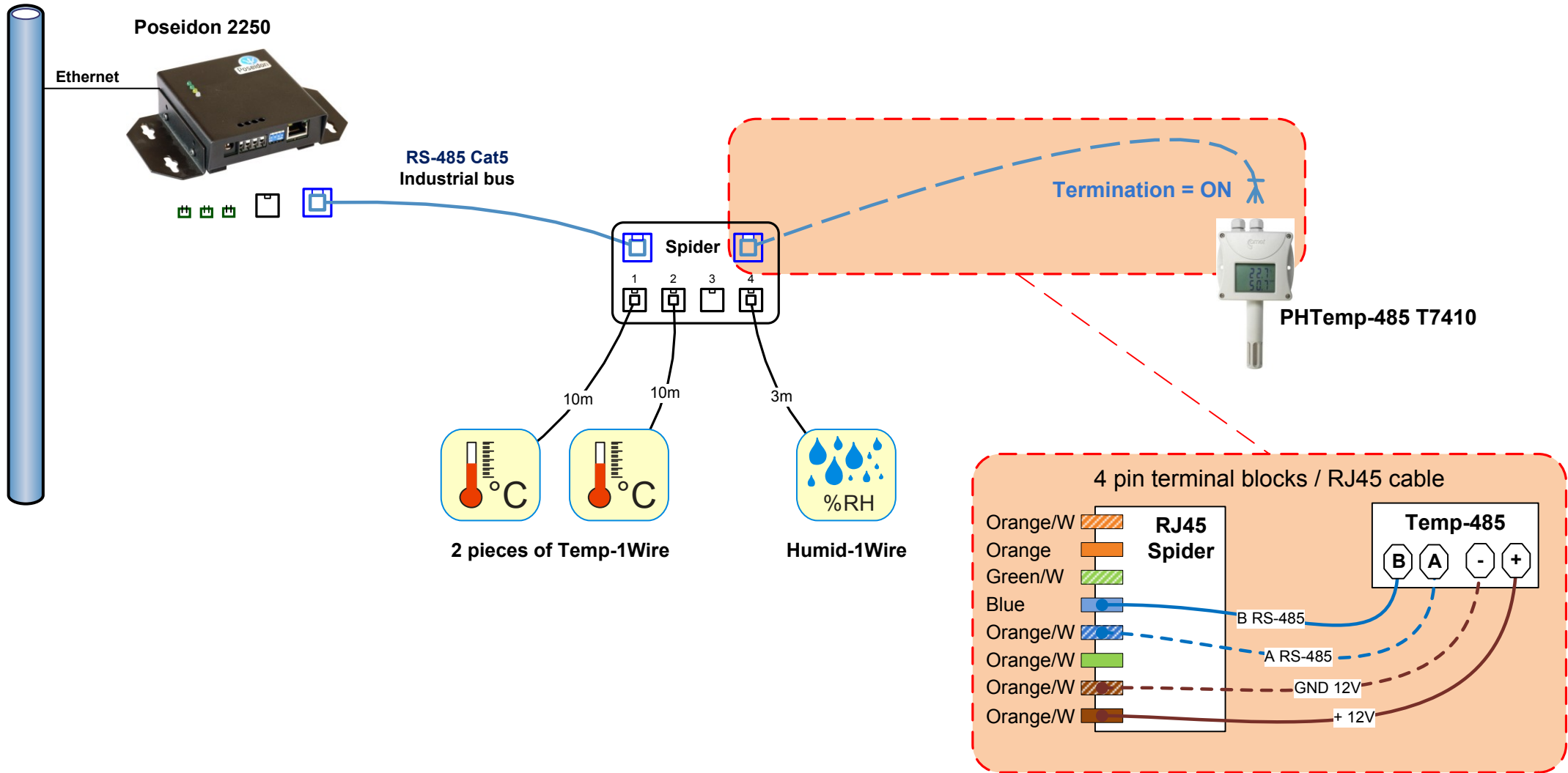

RJ45 Patch TP cable Cat5

RJ45 / 4 pin cable

Brown = +12V, Brown/White = GND
Blue = B, Blue/White = A

4 pins, LAST (Terminated)

RJ45

(9) RS-485: 4 pin wiring in "daisy chain" + Termination

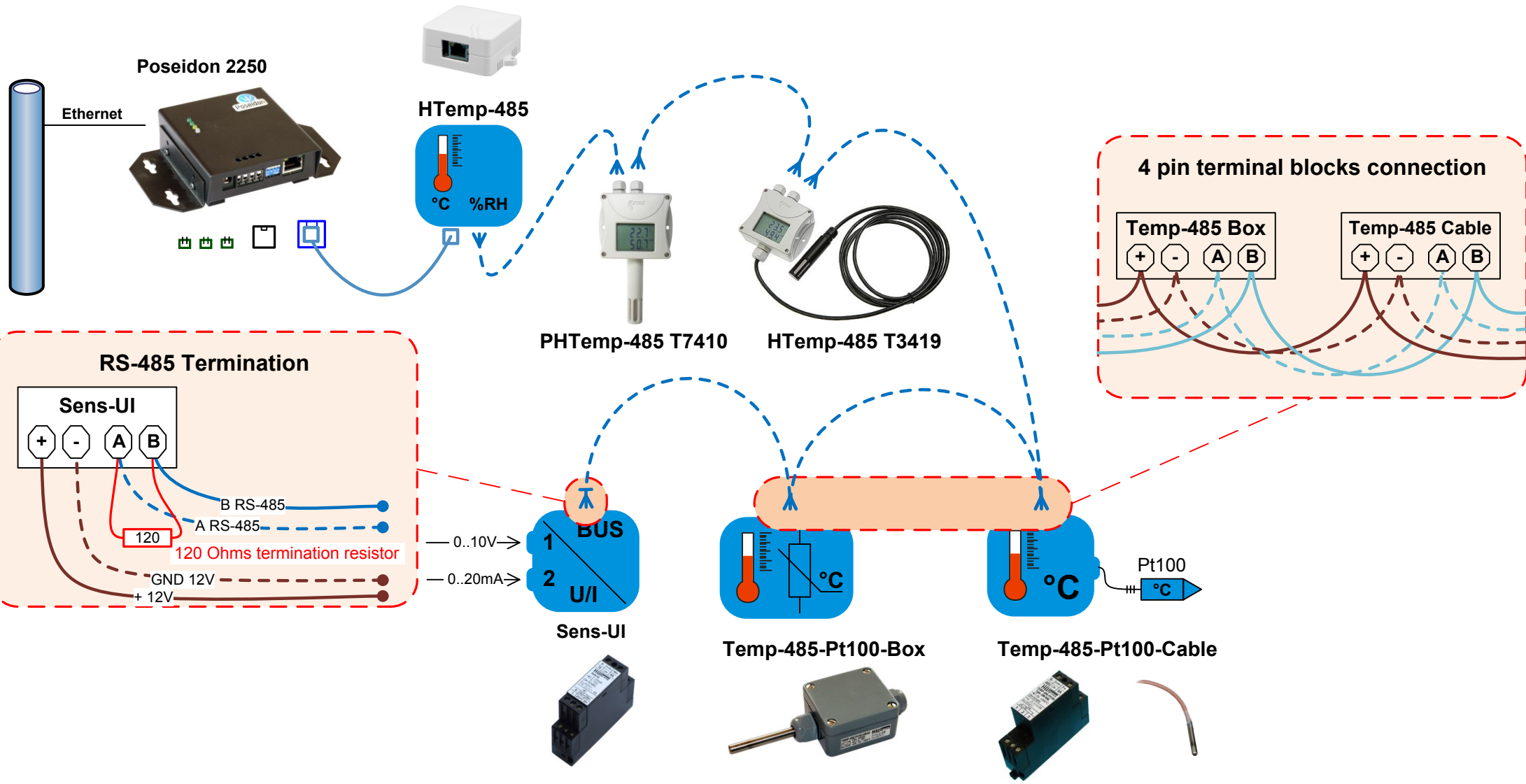

Cat5 TP cable, 2 pairs used
(power pair, RS-485 pair)

RJ45 / 4 pin cable
Brown = +12V, Brown/White = GND
Blue = B, Blue/White = A

RJ45 4 pins, LAST (Terminated)
4 pins TERMINAL BLOCK

(10) RS-485: 4 pin "daisy chain" all in one scheme

